

C. J. ADDY.

HEEL-BURNISHING MACHINE.

No. 169,884.

Patented Nov. 16, 1875.

Fig. 3.

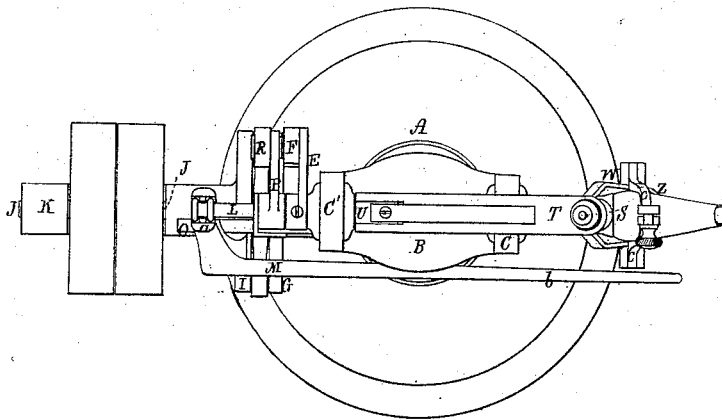
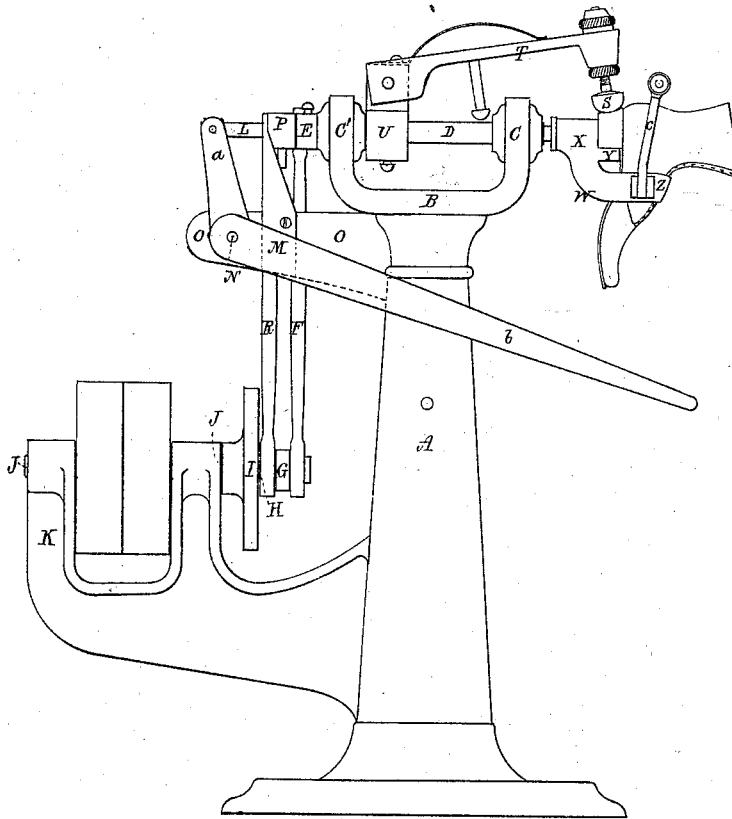

Fig. 1.



Witnesses.

W. C. Boardman
G. L. Hawkins

Charles J. Addy.
by his Attorney,
Fredrick Curtis

C. J. ADDY.
HEEL-BURNISHING MACHINE.

No. 169,884.

Patented Nov. 16, 1875.

Fig. 4.

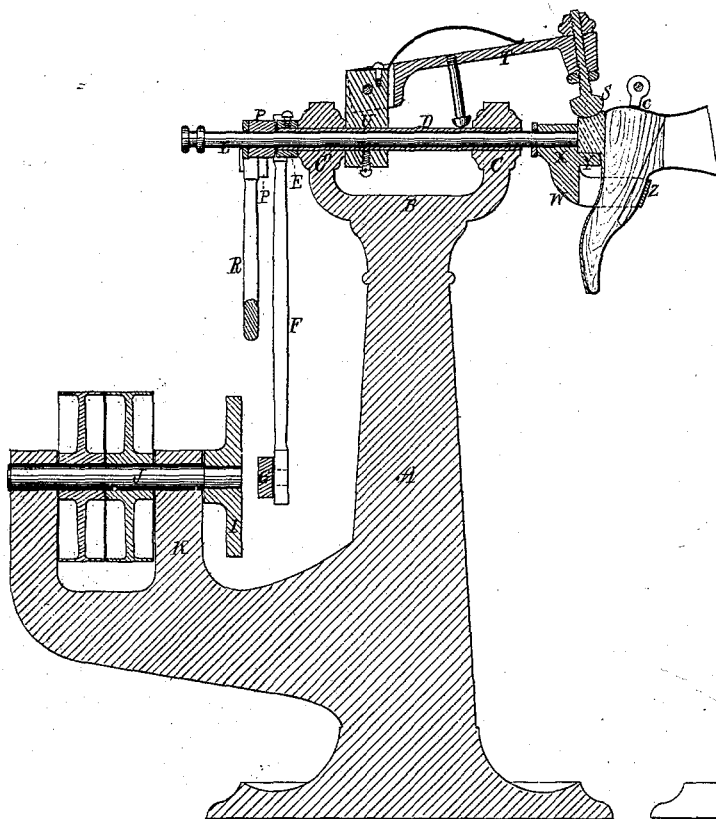
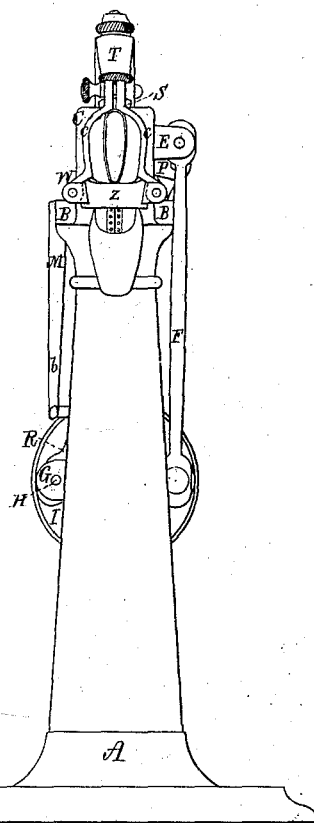

Fig. 2.



Witnesses.

W. C. Boardman.
G. C. Hawkins.

Charles J. Addy.

by his Attorney.
Frederick Cutler.

UNITED STATES PATENT OFFICE.

CHARLES J. ADDY, OF BOSTON, ASSIGNOR TO TAPLEY HEEL-BURNISHING MACHINE ASSOCIATION, OF LYNN, MASSACHUSETTS.

IMPROVEMENT IN HEEL-BURNISHING MACHINES.

Specification forming part of Letters Patent No. 169,884, dated November 16, 1875; application filed November 6, 1871.

To all whom it may concern:

Be it known that I, CHARLES J. ADDY, of Boston, in the county of Suffolk and Commonwealth of Massachusetts, have made an invention of certain Improvements in Heel-Burnishing Machinery; and do hereby declare the following description to embrace the nature, purposes, and advantages of my said improvements, and the manner in which the same are or may be carried into effect, due reference being had to the accompanying drawings, making part of this specification, and in which—

Figure 1 is a side elevation, Fig. 2 a front-end elevation, Fig. 3 a plan, and Fig. 4 a vertical central and longitudinal section, of a machine embodying my improvements.

First, this machine, in many of its features and in principle, bears strong resemblance to that shown in Letters Patent of the United States numbered 113,658, and issued on the 11th day of April, 1871, to Hawkins, Mead, and Spear, for improvements in boot and shoe heel burnishing machines; but a broad distinction is seen between the operations of the two machines, inasmuch as the boot-heel in the first remained stationary while the burnishing-tool described a curved sweep about it, while in my present machine both heel and burnishing-tool effect a movement in a curved path in opposite directions to one another, this elementary feature being the first point of novelty in the present application. Second, this invention consists in a novel construction of the jack or carriage, which receives the boot and supports it while subject to the action of the burnishing-tool, this second portion of the invention consisting of a yoke, into which the outer or toe portion of the boot is inserted as far as the instep, or thereabout, of a shoe, making part of the head or base of the yoke, and upon which the heel rests, and finally of a clamp composed of two dually arranged curved arms, which meet over the heel of the boot, and clasp the same with considerable power, the upper extremities of these arms being drawn together by a clamp-screw or other means, and the yoke itself being supported upon the outer extremity of a horizontal rocker-shaft duly mounted in the body or

head-stock of the machine, and to which reciprocating semi-rotary motion is imparted by a crank and connection-rod, as hereinafter stated, the purpose of this portion of the invention being to obtain a powerful, simple, and easily-adjusting device for holding the boot. Third, these improvements consist in the employment of two horizontal rock-shafts, supported by the head-stock of the machine, and traveling one within the other in opposite directions, one carrying the boot, as before stated, and the other the burnishing-tool, and both operated by connecting-rods and cranks, as hereinafter explained, the purpose of this third portion of the invention being to obtain reciprocating semi-rotary or vibratory movements of both heel and burnisher, as this motion has been found to possess several advantages. Fourth, these improvements consist in the employment, with heel-burnishing machine in which the boot travels, of a lever of more or less power, so combined and arranged, with respect to the boot-supporting jack or carriage and the burnishing-tool, as to enable the attendant to easily control the operation of presenting such boot, after being jacked, to the action of the burnishing-tool, or of withdrawing the boot after receiving the action of the burnisher.

The drawings accompanying this specification represent at A the main support or standard of the machine, which consists of an upright tapering shaft or column, with a substantial base, and surmounted by a cap consisting of a base or bed plate, B, and two end standards or uprights, C C', the plate B and uprights C C' being substantially in the form of the head-stock of a turning-lathe, the resemblance to a turning-lathe being continued by the addition to the head-stock of an arbor, as shown at D, and which bears the burnishing-tool carrier, as hereinafter explained.

In carrying my improvements into effect I proceed as follows: The arbor D, above named, is a tubular shaft, and protrudes a short distance rearward of the standard C', where it is furnished with a horizontal arm, E, projecting laterally from it, to the outer end of which the upper extremity of a pitman, F, is pivoted, the lower termination of such pitman being

pivoted to the wrist of a crank-arm, G, the inner end of such arm being mounted and fixed upon a lateral stud, H, applied to the front face of a crank-wheel, I, the wheel being mounted upon the front end of a horizontal driving-shaft, J, which is supported by and revolves in a bracket or "tail-stock," K, projecting rearward from the lower part of the column A.

Within the hollow arbor D I dispose a rocker shaft or spindle, L, the front end of which extends somewhat beyond the standard C, and has affixed to it the jack hereinbefore alluded to, the rear end of the spindle L likewise projecting beyond the rear standard *c'* and the arbor D, and having its extremity swiveled in a suitable manner to the upper arm *a* of a bent lever, M, such lever being fulcrumed to a pivot, N, projecting laterally from an offset, O, which departs from the rear side of the column A immediately below the head-stock, the lower and longer arm *b* of the lever M extending alongside of the column and into a position to be easily grasped by the attendant. By elevating or depressing the arm *b* of the lever M the spindle L is advanced or retracted as desired. P in the accompanying drawings represents an arm, which is disposed alongside the arm E before named, and is mounted upon the spindle L in such manner that the spindle may slide easily within it, the connection between the two being a spline and groove one, in order that the arm P, while sliding upon the spindle, shall, by its vibrations, effect the necessary rockings of such spindle. To the outer end of the arm P the upper extremity of a pitman, R, is pivoted the lower end of such pitman being in turn pivoted to the stud H of the wheel I, which has been hereinbefore alluded to, the two arms P and E, as well as the pitman F and R, being of substantially like length and disposition, except that the lower pivots of the two pitmen are disposed at opposite sides of the wheel I, the space intermediate between the arm E and the face of the wheel being sufficient to admit the pitman R and permit it to travel in a circular path. Owing to the above-described arrangement of the pitmen F and R with respect to each other, the wheel I and arms E and P, a revolution of such wheel has the effect of imparting semi-rotary reciprocating movements to the arbor D and spindle L in directions opposite to one another; consequently the burnishing tool and jack travel in like manner. The said burnishing-tool is shown at S in the drawings as mounted in an adjustable manner upon the forward end of a horizontal presser-bar or carrier, T, the rear end of such carrier being pivoted to a block, U, which encompasses the tubular arbor D, preferably, between the standards *c c'* of the head-stock, the presser-bar T and its burnishing-tool being depressed toward the boot heel or jack by a spring suitably applied. The jack hereinbefore alluded to as constituting one portion of this inven-

tion is shown at W in the drawings as composed of a head or base, X, affixed to the front end of the spindle L' of a shelf, Y, situated below the burnishing-tool, and projecting horizontally forward from the lower part of such base, to receive the boot-heel of a yoke or clasp, z, which also extends horizontally forward, or practically so, from the lower part of the head and below the shelf Y, and, finally, of two oppositely-disposed upright curved arms, *c c*, which spring from the side of the yoke, such arms meeting at top and being joined by a screw or its equivalent in an adjustable manner, in order to allow the arms to be readily separated and thrown aside to remove the boot. The drawings represent in Fig. 1 the manner in which the boot is placed within the jack—that is to say, as having its foot portion passed into the yoke until its instep brings up against such yoke, as having its heel resting upon the shelf Y, and abutting against the head or base X of the jack, and with the arm *c c* embracing opposite sides of the heel portion of the foot, a last being inserted within the boot previous to its being "jacked." While applying or "jacking" the boot the lever-arm *b* is depressed, which advances the spindle L and the jack, and removes it from contact with the burnishing-tool. The boot being jacked, the lever-arm *b* is elevated, and by the act the boot-heel is advanced to a position below the burnishing-tool, and so that the latter shall impinge upon its surface or edge. The driving-shaft being put in rotation the arbor and spindle, by means before stated, move in opposite directions, and the heel, by the act, receives a polished surface, heat being applied in a suitable manner to the burnishing-tool to hasten and heighten the effect.

The above-described arrangement of jack enables the operator to stand closely up to the boot, and to watch and guide its movements very advantageously.

The employment of a last within the boot supports the latter in a firm and unyielding manner, and is productive of other advantages.

I claim—

1. A machine for burnishing the heels of boots and shoes, in which the boot support or jack and the burnisher are combined with mechanism for actuating the same, arranged and operating substantially in the manner herein shown and described, to impart to the two simultaneously-vibrating movements in a curved path, but in opposite directions, for the purposes set forth.

2. The combination, with the boot-jack and the burnishing-tool, of the spindles or shafts for supporting the same, and the mechanism, substantially as herein shown and described, for imparting to said shafts simultaneously vibratory or rocking movement in opposite directions for the purposes stated.

3. The combination of the boot-jack and burnisher with their supporting spindles or

shafts when arranged the one within the other, so as to vibrate or rock upon the same axis, substantially as herein shown and set forth.

4. The combination of the boot support or jack, with a rocker-shaft which carries the same, and is capable of sliding longitudinally, substantially as shown and described, for the purpose of moving the jack toward or away from the burnishing-tool.

5. The combination, with the jack and the sliding rocker shaft or spindle which carries the same, of the means, substantially as herein shown and described, for producing the sliding movement of said spindle.

6. The jack herein described, consisting of the boot-supporting yoke, the boot-holding

clamp, and the rest for the heel-tread, said parts being arranged to receive and support the boot, substantially in the manner herein shown and set forth.

7. In combination the jack herein explained, the burnishing-tool and its carrier, the arbor D and spindle L', the lever M or its equivalent, the arms P and E, pitmen F and R, crank arms G, and wheel I or its equivalent, the whole operating in manner and for purposes substantially as stated.

CHARLES J. ADDY.

Witnesses:

EDW. GRIFFITH,
FREDERICK CURTIS.